

exhaust outlet size

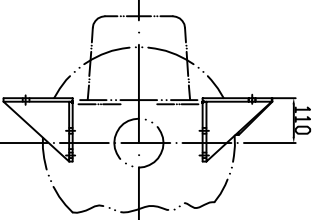
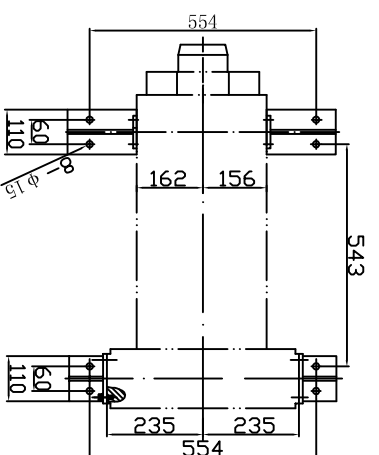
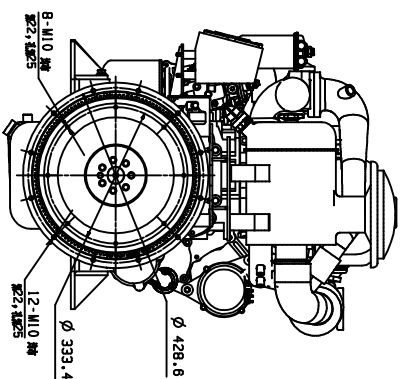
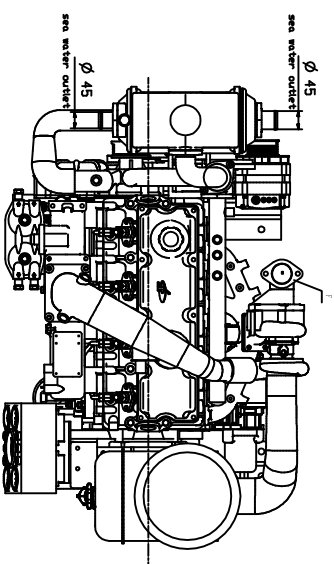
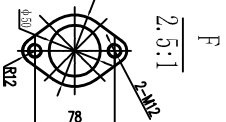

### YC4D series marine engine installation drawing

YC4108ZC\YC4D75C series marine engine installation drawing  
 一、Flywheel housing: SAF3#  
 二、Flywheel: SAH11.5"

三、specification of sea pump:

1、model: 6135Ca.

2、specification:

(1) flow:  $Q=220l/min$ , (2) speed:  $n=2800r/min$ ,

(3) head:  $H \geq 15m$ , (4) suction

Hft:  $h \geq 1m$ , (5) power:  $N=1.84kW$ .

1	2	3	4	5	6	7	8	9	10	11	12
6	F	E	D	C	B	A					

玉柴机器有限公司  
 YUCHAI MACHINERY CO.,LTD.  
 51